

NanoQuest

USER GUIDE



Contents

1. INTRODUCTION.....	1-1
1.1 Key Features.....	1-1
1.2 User Card Options.....	1-1
2. Installation.....	2-1
2.1 Box Contents.....	2-1
2.2 Tools Required.....	2-1
2.3 Choosing a Location.....	2-1
2.4 Mounting the NanoQuest.....	2-1
2.5 Wiring the NanoQuest.....	2-2
2.5.1. Power Supply Connection.....	2-3
2.5.2. Wiring the NanoQuest for Basic Operation.....	2-4
2.5.3. Fitting the Cover.....	2-5
2.6 Power Up and Confidence Check.....	2-5
3. Basic Configuration of the NanoQuest.....	3-1
3.1 Programming Modes.....	3-1
3.2 Card Types.....	3-2
3.2.1. User Cards.....	3-2
3.2.2. Auxiliary Cards.....	3-2
3.3 Programming Guide Key.....	3-2
3.4 Adding User Cards.....	3-3
3.5 Adding Auxiliary Cards.....	3-5
3.6 Deleting User & Auxiliary Cards.....	3-7
3.7 Add a 2nd Master Card.....	3-9
4. Basic Operation.....	4-1
4.1 Door Open (Strike) Time.....	4-1
4.1.1. Using Door Open (Strike) in Toggle Lock Mode.....	4-2
4.2 Protecting Multiple Doors.....	4-3
5. Door Monitoring & Door Alarms.....	5-1

5.1 Door Forced Alarm.....	5-1
5.2 Alarm Output Operation.....	5-1
5.3 Door Contacts.....	5-2
5.3.1. Wiring.....	5-2
5.3.2. Configuration.....	5-2
5.4 Alarm Output.....	5-3
5.4.1. Wiring.....	5-3
5.4.2. Configuring the Alarm Output.....	5-4
6. Controlling Additional Devices.....	6-1
6.1 Using the Auxiliary Output to Operate an Intruder Alarm.....	6-1
6.2 Auxiliary Output Wiring.....	6-2
6.3 Configuring the Auxiliary Output.....	6-3
6.4 Controlling Other External Devices.....	6-4
6.5 Using the Auxiliary Output as a Master Lock.....	6-4
7. Auxiliary Input.....	7-1
7.1 Auxiliary Input Wiring.....	7-1
8. Silent Mode.....	8-1
8.1 Configuring Silent Mode.....	8-1
9. Miscellaneous Features.....	9-1
9.1 General.....	9-1
9.2 Deleting all User Cards and Auxiliary Cards.....	9-1
9.2.1. Procedure for Deleting all Cards.....	9-1
9.3 Resetting to Factory Default Settings.....	9-2
9.3.1. Performing a Factory Reset.....	9-2
9.4 Wiegand Data Output Option.....	9-3
9.5 RS232 Data Output.....	9-3
10. Technical Specifications.....	10-1

1. INTRODUCTION

The NanoQuest is an easy-to-install standalone access control system housing both the access control electronics and reader technology in a single compact unit. A single NanoQuest unit can control access through one door for up to 500 authorised users. In addition to providing access control, the NanoQuest can be used as a secure method of controlling devices such as intruder alarm panels, lighting and heating. It can also control external alarm devices such as a siren or flashing light when one of the predefined alarm conditions occurs.

The configuration of features and the addition/removal of User cards are simple operations using a 'Master' card. Special 'Auxiliary' cards can also be added to control auxiliary devices.

The NanoQuest can also output card data in RS232 format to an external system while it controls access autonomously. This can be used to monitor the use of cards or provide additional control. It can also be set to 'Reader' mode where it simply outputs card data in both RS232 and 26-bit Wiegand format so that it can be used as a standard reader connected to an external controller in any future migration to a larger system.

Note: This manual can also be used as a reference for the programming and operation of the Slimline version of the NanoQuest as long as you take into account that LED indications are slightly different (substitute 'Amber' with 'Red and Green together').

1.1 Key Features

- Up to 500 users
- Compact unit
- Very easy to install
- Simple programming of features
- Free exit input
- Arming input
- Suitable for internal and external use
- Auxiliary output for controlling intruder alarm panels, lighting & heating, etc.
- Alarm/Incident output
- RS232 serial card data output for monitoring and/or external control
- 26-bit Wiegand output to allow migration to a larger system

1.2 User Card Options

Where only a small number of user cards are to be issued and it is not essential to have a means of removing lost or stolen cards from the NanoQuest, cards can be purchased as simple 10-card packs. The cards can be individually enrolled into the NanoQuest when they are required.

For installations requiring many user cards, we recommend the purchase of our card packs that are supplied in filing wallets, where each card comes with duplicate 'administration' card. A batch enrolment card is also supplied within the pack so that the whole batch of cards can be enabled in a

single procedure (cards can also be enrolled individually, if required). If a card is lost or stolen, then the corresponding administration card can be used to remove that card from the NanoQuest.

Note: Where two or more NanoQuests are used in the same project (including those with multiple sites), each user card can be enrolled into as many NanoQuests as necessary to provide appropriate access rights to the cardholder. Furthermore, the cards can also be used on a networked access control system that has compatible card readers.

2. Installation

2.1 Box Contents

Before installation, check that the box contains the following items:

1 x NanoQuest (2-part) unit and cable	2 x mounting screws (No.6 x 1.25")
1 x cover securing screw	2 x Master proximity cards
1 x varistor	1 x mounting template

You will also need unassigned cards or card packs purchased separately.

The NanoQuest requires a power supply of between 9 and 16V DC. The package does not include a mains adaptor, so we recommend that an appropriate 12V DC power supply unit or mains adaptor is made available to supply power to the NanoQuest. The NanoQuest requires less than 70mA at 12V.

2.2 Tools Required

Installing the NanoQuest requires only a basic tool kit, including:

Terminal screwdriver

Pozidrive screwdriver

Drill with drill bits suitable for cable aperture.

2.3 Choosing a Location

The NanoQuest should be located as close to the controlled access point as possible, and should be fitted at the most convenient height and position for all users to present their cards to on the way to the controlled access point. Other factors to consider are the proximity to the power supply, cabling to the door contact and door lock, and connections to external equipment.

2.4 Mounting the NanoQuest

The NanoQuest comprises two part; the reader body and the front cover. Before mounting the NanoQuest, you must separate the two parts as follows:

Ensure that the securing screw is not fitted to the base of the NanoQuest.

Insert the tip of a terminal screwdriver into the small slot next to the screw hole and press lightly to release the securing catch while you separate the cover from the body at the base.

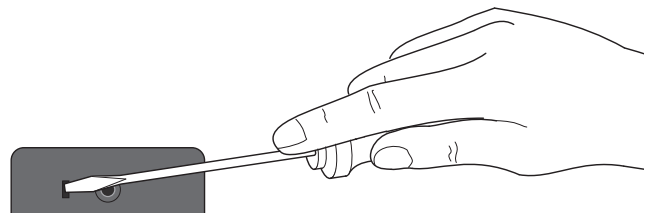

Two mounting screws are provided to mount the NanoQuest onto a wooden door frame. For mounting on plaster or concrete walls, use an appropriate masonry drill and wall plugs to match the mounting screws.

Use the supplied template to mark out the position of the cable hole and screw fixings. Drill a suitably sized hole through which the cable can be fed and drill and prepare the top fixing hole. Feed the cable through the cable hole so that the unit can be positioned correctly against the mounting surface. Fit the unit and partially tighten the top fixing screw.

Ensure that the unit is level and check the position of the bottom fixing hole. Remove the unit and drill and prepare the bottom fixing hole.

Feed the cable through to a convenient termination point inside the secure area (it is recommended that the cable is terminated inside the power supply unit enclosure or within a tamper-proof terminal block) Secure the reader in position with both mounting screws.

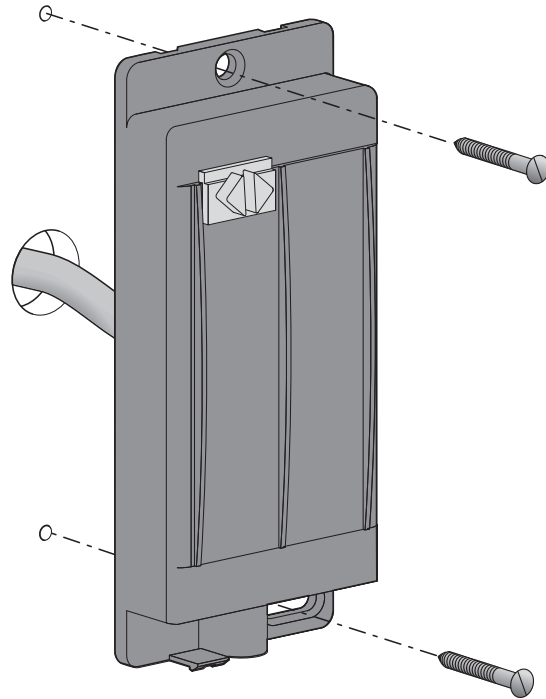

2.5 Wiring the NanoQuest

Cables can now be run from the termination point to the power supply unit, locking device and free exit button (if fitted). Other connections may also be required depending upon the specific application. These may include:

- Door monitoring contacts (Section 5)
- External alarm sounder/indicator (Section 5)
- Auxiliary Device output (e.g. Alarm panel) (Section 6)
- Auxiliary Input (Section 7)

For the wiring information of these additional items, refer to the appropriate section of this manual.

The wire assignments are as follows:

Colour	Function
Red	9 to 16V DC
Black	0V
White/Black	Request to Exit
Orange	Door Monitor
Orange/Black	Relay common
Green/White	Normally open contact
Blue/White	Normally closed contact
Green	Auxiliary out (500mA Max.) / Wiegand Data 0
White	Wiegand Data 1
Blue	Alarm out (500mA Max.)
Red/Black	Auxiliary in
Green/Black	RS232 serial data output (10 digits plus CR)
Blue/Black	Wiegand output (Reader Mode) select

2.5.1. Power Supply Connection

Connect to a suitable Power Supply Unit as shown below:

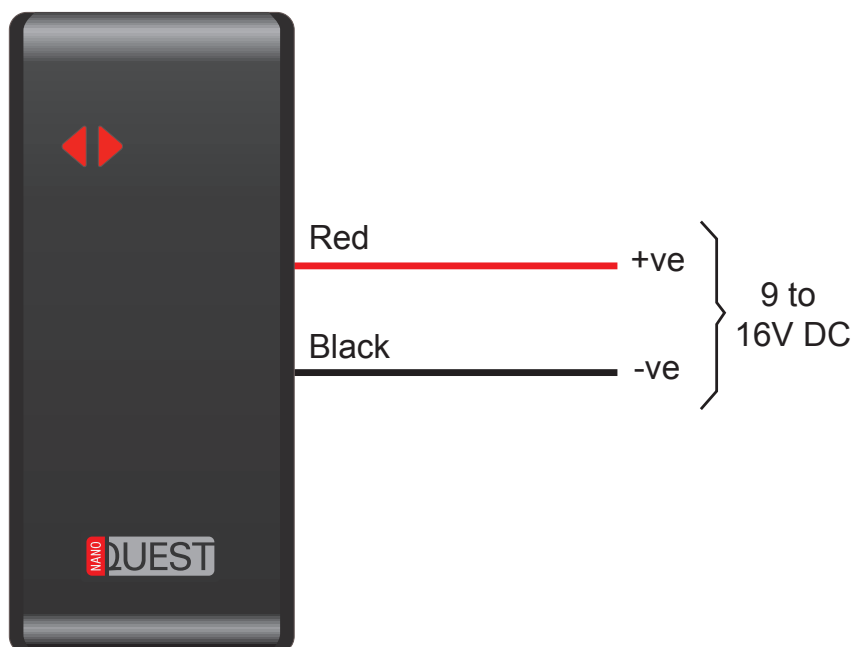

2.5.2. Wiring the NanoQuest for Basic Operation

The changeover relay contacts allow both fail-safe and fail-secure operation:

Normally Closed Contacts

The normally closed contacts are used for magnetic locks and fail-safe door strikes. Power is applied in the locked state.

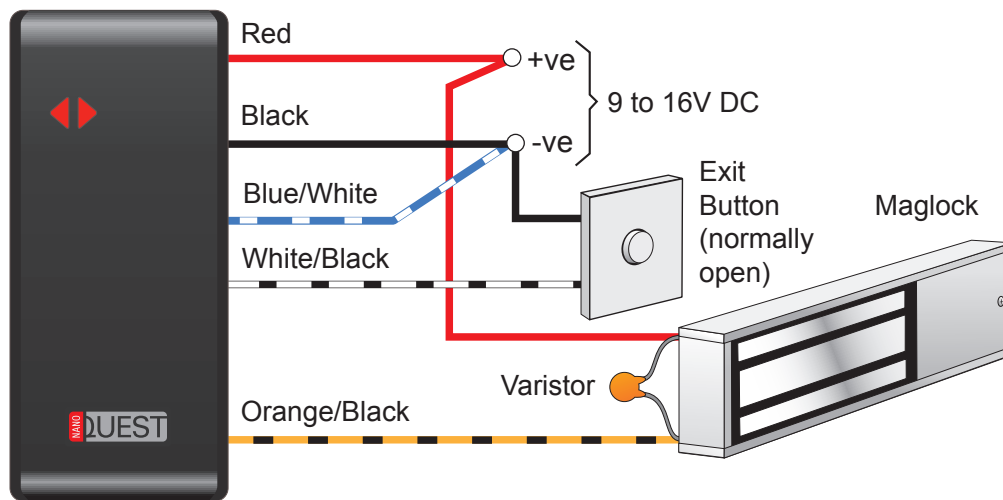

Normally Open Contacts

The normally open contacts are used for fail-secure door strikes. The power is applied in the unlocked state.

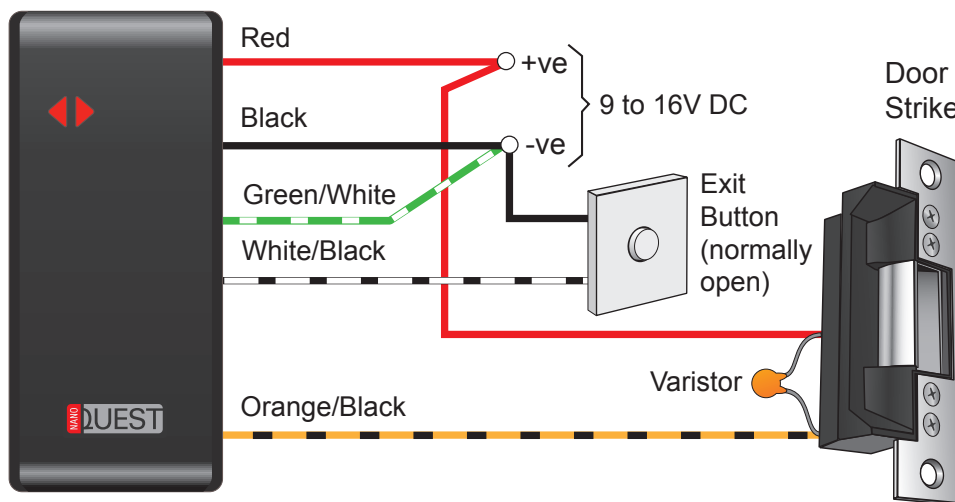

WARNING

You must always fit the varistor across the load as close to the locking device as possible. This will protect the NanoQuest from back EMF. The NanoQuest warranty does not cover damage caused by failure to fit the protection device.

If a door strike is used and a door handle is left in use on the inside of the door, connection to the free exit button may not be required.

2.5.3. Fitting the Cover

Once the NanoQuest has been fitted and wired, the cover can be fitted as follows:

1. Hook the two tabs at the top of the cover over the top of the backplate, engaging them with the corresponding slots in the backplate.
2. Hinge the cover over the NanoQuest body until it is correctly seated over it (clicks into place).
3. Insert the cover retaining screw in the base of the unit and tighten.

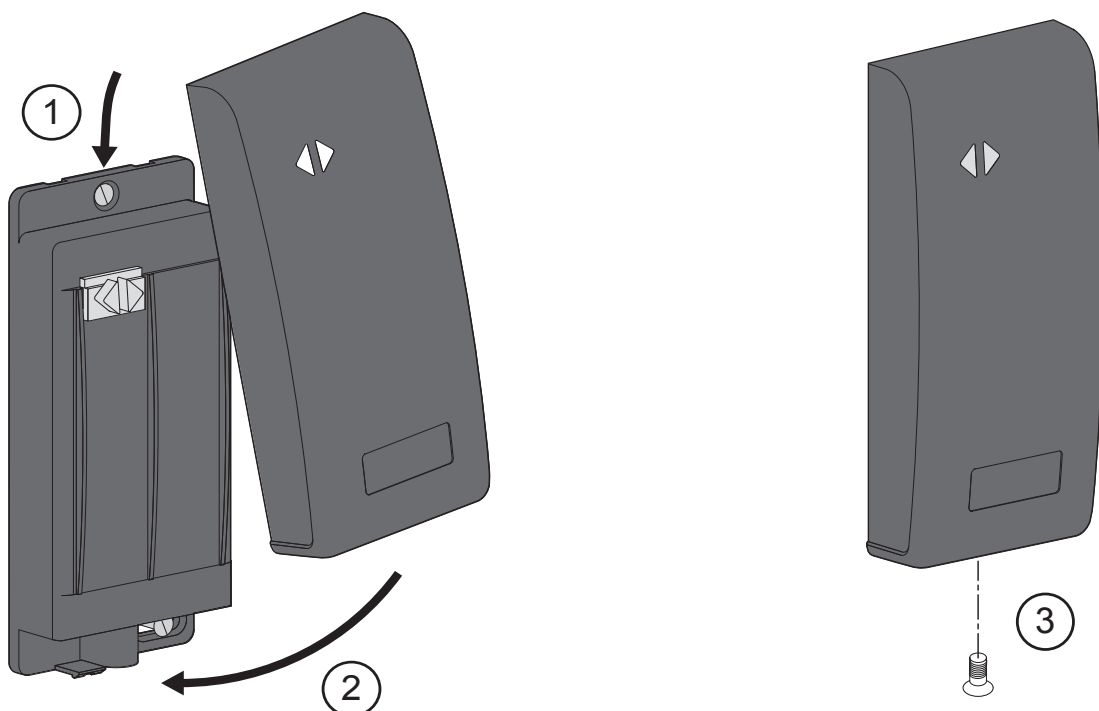

2.6 Power Up and Confidence Check

Apply power to the unit and check that the LED lights up red.

Present a Master Card once to the face of the unit and check that the buzzer gives two short beeps and the LED blinks green and then continue to flash red. Wait 30 seconds. The buzzer should give two short beeps and the LED returns to a steady Red.

Press the Free Exit Button, if fitted. The NanoQuest will give a short beep, the lock will release for 3 seconds and the LED changes to green during this period. This indicates that the unit is functioning correctly.

3. Basic Configuration of the NanoQuest

Once the physical installation of the NanoQuest is complete, User cards must be added and the unit must be configured so that the functions operate according to the specific application.

3.1 Programming Modes

Two Master cards are supplied with the NanoQuest. These must be kept safe as they are required to enable programming. By presenting a Master card to the reader, you can enter the programming modes.

There are nine programming modes, the first of which is entered by presenting the Master card to the NanoQuest once (buzzer gives 2 short beeps and LED flashes green). While in this mode, the LED flashes red. Subsequent presentations of the Master card will step through the other programming modes. The buzzer will beep once and the LED will flash green to confirm each step.

i While in programming mode, the LED indicate the current mode by a sequence of red flashes followed by a pause. The sequence is repeated continuously while in that mode. The number of flashes in the sequence corresponds with the programming function number as shown in the table below.

Note: The unit will return to Operating Mode after 30 seconds of inactivity. The unit can also be returned to Operating Mode by presenting a Master card after a value has been set in any of the Programming Modes.

The following table is a summary of how the programming modes function:

Programming Function	Present Master	Programming Operations/Actions	Default Value
1 Add user card(s)	Once	Present card(s) to make valid	
2 Add Aux. card(s)	Twice	Present card(s) to make valid	
3 Delete card(s)	3 times	Present card(s) to delete	
4 Add 2nd Master	4 times	Present unregistered card	
5 Configure alarm Output	5 times	Set to Latch - present a User card once Set to Pulse - present a User card twice	Latch
6 Configure aux. Output	6 times	Set to Latch - present a User card once Set to Pulse - present a User card twice	Latch
7 Use door contact	7 times	Not used - present a User card once Used - present a User card twice	Not used
8 Silent mode	8 times	Off - present a User card once On - present a User card twice	Off
9 Set relay strike time	9 times	Present a User card once per second of strike time. For 0.5 seconds present a User card 11 times. For latching mode present a User card 12 times.	3 sec's

Example 1 - To add card 'N' as a User card:
Present a Master card once, present card 'N', present the Master card once again.

Example 2 – Set to buzzer to 'Silent Mode' using valid card 'V':
Present a Master card 8 times, present card 'V' twice, present the Master card once again.

The rest of this section provides a full explanation of each of the basic programming functions.

3.2 Card Types

In order to fully utilise the NanoQuest system, three different card types are used. Master cards are used for accessing the programming menu as described in section 3.1. The two remaining card types are ‘User cards’ and ‘Auxiliary cards’.

3.2.1. User Cards











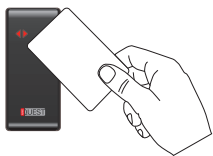

User cards should be provided to those people that have permission to access to the area protected by the NanoQuest unit. Once a card has been added to the NanoQuest as a User card, the NanoQuest will unlock the door and grant access whenever that card is presented to it. Each User card can be added to multiple NanoQuest units. This therefore enables each person to gain access through multiple doors using one common User card.

3.2.2. Auxiliary Cards

Auxiliary cards operate in the same way as User cards for access through doors but have the additional function of controlling the Auxiliary output. The Auxiliary output is typically used to arm an intruder alarm system by the person who is last to leave the building and to disarm it by the person who is first to arrive (see Section 6).

3.3 Programming Guide Key

The following programming instructions include a pictorial representation on the right for quick reference. They show the type of card and number of times it is presented to the reader together with the resulting indications. The meanings of the symbols used are as follows:

				
Present Master Card	Present User Card	Present Auxiliary Card	Present Unassigned Card	Present Batch Card
				
LED glows steady red	LED briefly glows red	LED briefly glows green	LED glows green for fixed period	LED dims for fixed period
				
LED dims momentarily	Short beep	Long tone	Continuous tone	







3.4 Adding User Cards

Each proximity card supplied with the NanoQuest carries a unique identity number. For a card to function as a User card at the NanoQuest, its identity must be either individually 'learnt' into the NanoQuest as as a User card or added as part of a batch of User cards using a batch card.

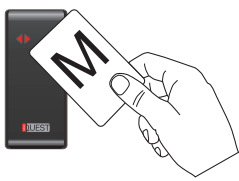
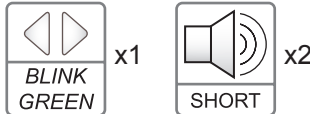
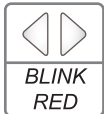
You can add as many User cards as you need to the system at one time by presenting each card individually while the NanoQuest is in "Add User Card" mode. We recommend that you add new User cards only when they are required. This avoids the risk of loss or theft of valid User cards from stock.

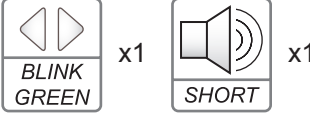
If you have a batch card and you wish to add the full batch of cards at the same time, you simply need to present the batch card to the NanoQuest while it is in "Add User Card" mode.

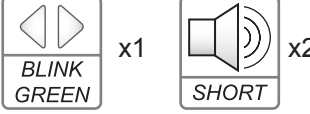
The procedure for adding User cards is as follows:

Description	Action	Indication	Final State
<p>1) Enter 'Add User Card' mode by presenting the Master card once.</p> <p>The LED blinks green and the unit beeps twice to indicate programming mode has been entered successfully.</p> <p>The LED flashes red regularly to indicate Mode 1</p>			 <p>Followed by a pause. Sequence is repeated.</p>
<p>2) Adding Individual Cards</p> <p>Present a card not currently added on the system.</p> <p>The LED blinks green and the unit beeps to signify that the card has been successfully added as a User card.</p> <p>Repeat this step for each additional card.</p>			As above
<p>2) Adding a Batch of Cards</p> <p>Present the batch card.</p> <p>The LED glows green while the cards are being added. The unit beeps when all cards have been added.</p>		As above	As above
<p>3) Present the Master card at any time to exit programming mode.</p>			 <p>(Operating mode)</p>

When adding User cards, if an existing User card is presented, the NanoQuest will respond as normal, but no changes are made to the system or the card. If an existing Auxiliary card is presented however, its Auxiliary privileges will be removed and the card will be downgraded to a normal User card. The unit will then allow you to continue adding cards.

While in 'Add User Card' mode , if you do not present any cards for a period of thirty seconds, the NanoQuest will exit programming mode and return to normal operation.









3.5 Adding Auxiliary Cards

For a card to function as an Auxiliary card, it must be either individually ‘learnt’ into the NanoQuest as an Auxiliary card or added as part of a batch of Auxiliary cards using a batch card.

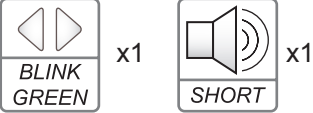
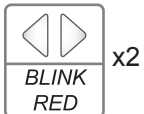
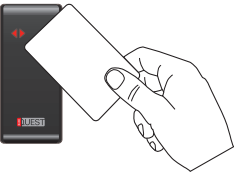
You can add as many Auxiliary cards as you need to the system by presenting each card individually while the NanoQuest is in “Add Auxiliary Card” mode. We recommend that you add new Auxiliary cards only when they are required. This avoids the risk of loss or theft of valid cards from stock.

If you have a batch card and you wish to add the full batch of cards as Auxiliary cards, you simply need to present the batch card to the NanoQuest while it is in “Add Auxiliary Card” mode.

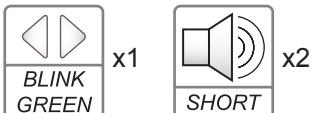
The procedure for adding Auxiliary cards is as follows:

Description	Action	Indication	Final State
<p>1) Enter ‘Add Auxiliary Card’ mode by presenting the Master card twice.</p> <p>The LED blinks green and the unit beeps twice to indicate programming mode has been entered successfully. The LED then blinks green once and unit beeps once for the second presentation.</p> <p>The LED repeats a sequence of 2 red flashes followed by a pause to indicate Mode 2.</p>	 <p>x2</p>	<p>First presentation:</p>  <p>Second presentation:</p> 	 <p>Followed by a pause. Sequence is repeated.</p>
<p>2) Adding Individual Cards</p> <p>Present a card not currently added on the system.</p> <p>The LED blinks green and unit beeps to signify that the card has been successfully added as an Auxiliary card.</p> <p>Repeat this step for each additional Auxiliary card.</p>			<p>As above</p>
<p>2) Adding a Batch of Cards</p> <p>Present the batch card.</p> <p>The LED glows green while the cards are being added. The unit beeps when all Auxiliary cards have been added.</p>		<p>As above</p>	<p>As above</p>
<p>3) Present the Master card to exit programming mode.</p>			 <p>(Operating mode)</p>

When adding Auxiliary cards, if an existing Auxiliary card is presented, the NanoQuest will respond as normal, but no changes are made to the system or the card. If a User card is presented however, it will be upgraded to an Auxiliary card. The unit will then allow you to continue adding cards.













While in 'Add Auxiliary Card' mode , if you do not present any cards for a period of thirty seconds, the NanoQuest will exit programming mode and return to normal operation.

3.6 Deleting User & Auxiliary Cards

Any number of previously added User and Auxiliary cards can be deleted from the system by presenting each card individually while in the “Remove Card” mode. Any card deleted from the system can be re-added as a User or Auxiliary card again in the future.

If the security of the site is critical, the storage of unused User and Auxiliary cards is not recommended. You may wish to delete unused cards from the system until a later date.

The procedure for removing cards is as follows:

Description	Action	Indication	Final State
<p>1) Enter ‘Remove Card’ mode by presenting the Master three times.</p> <p>The LED blinks green and the unit beeps twice to indicate programming mode has been entered successfully. The LED then blinks green once and the unit beeps once on the second and subsequent presentations.</p> <p>The LED repeats a sequence of 3 red flashes followed by a pause to indicate Mode 3.</p>	 <p>x3</p>	<p>First presentation:</p>   <p>Second and subsequent presentations:</p>  	 <p>x3</p> <p>Followed by a pause. Sequence is repeated.</p>
<p>2) Present either a User or Auxiliary card.</p> <p>The LED blinks green and the unit beeps to signify that the card has been successfully removed.</p> <p>Repeat this step for each additional User or Auxiliary card that you wish to remove.</p>		 	<p>As above</p>
<p>3) Present the Master card at any time to exit programming mode.</p>		 	 <p>(Operating mode)</p>

When deleting cards, if an unassigned card is presented, the NanoQuest will respond as normal, but no changes are made to the system or the card.

While in ‘Remove Card’ mode, if you do not present any cards for a period of thirty seconds, the NanoQuest will exit programming mode and return to normal operation.











Note: If you wish to remove a batch of cards, this can be done by presenting the corresponding batch card to the NanoQuest at step (2) in the above sequence. Please be aware that all cards in the batch will be removed and will not function as either User cards or Auxiliary cards on the NanoQuest.

3.7 Add a 2nd Master Card

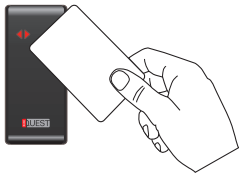
A maximum of 2 Master cards can exist at any one time. If either of the supplied Master cards are lost, a new Master card can be added using the remaining Master card. If an attempt to add a third Master card is made, the missing Master card (i.e. not the one used to enter programming mode), is replaced. This means that a lost Master card can always be replaced providing you are still in possession of the other Master card.

Note: If both Master cards have been lost, the NanoQuest must be reset to factory default settings and new Master cards created (refer to section 9).

The procedure for adding a 2nd Master card is as follows:

Description	Action	Indication	Final State
<p>1) Enter 'Add 2nd Master Card' mode by presenting the Master card four times.</p> <p>The LED blinks green and the unit beeps twice to indicate programming mode has been entered successfully. The LED then blinks green once and the unit beeps once on the second and subsequent presentations.</p> <p>The LED repeats a sequence of 4 red flashes followed by a pause to indicate Mode 4.</p>	 <p>x4</p>	<p>First presentation:</p>  x1  x2	 x4 <p>Followed by a pause. Sequence is repeated.</p>
<p>2) Present a card not currently added on the system.</p> <p>The LED blinks green and the unit beeps to signify that the card has been successfully added as a Master card.</p>		 x1  x1	<p>As above</p>
<p>3) Present the original Master card to exit programming mode.</p>		 x1  x2	 <p>(Operating mode)</p>







When adding a second Master card, if an existing User or Auxiliary card is presented, the NanoQuest will give a negative response and the card will not be upgraded to a Master card. The card must be deleted from the NanoQuest as described in section 3.6 before it can be added as a Master card.

While in 'Add 2nd Master Card' mode, if you do not present any cards for a period of thirty seconds, the NanoQuest will exit programming mode and return to normal operation.

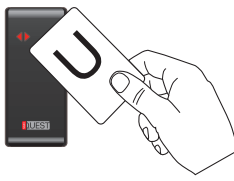
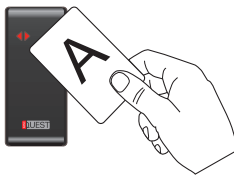
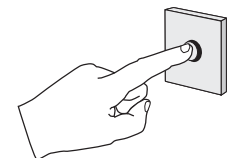
4. Basic Operation

As described in Section 3, both User and Auxiliary cards can be used to gain entry through a door protected by NanoQuest. A third way to release the door lock is by pressing the 'Request to Exit' button (if one is connected). A 'Request to Exit' button is normally used where it is necessary for entry to a controlled area to be via the use of valid proximity cards but there is no need to control the exit from the controlled area. The button would therefore be located inside the controlled area.

When the NanoQuest is in its normal operation mode (i.e. LED is continuously glowing red), the door lock can be released as follows:

Description	Action	Indication	Final State
<p>Present a User or Auxiliary card to the unit or press the 'Request to Exit' button.</p> <p>If the card is valid for this door (or if the Request to Exit button is pressed), the NanoQuest will beep and the door will unlock for the 'Door Open (Strike) Time'. The LED will glow green while the door is unlocked. The unit will then return to normal operation.</p> <p>If the card is not valid for this door, the unit will output a long error tone, the LED will turn off briefly and the door will not unlock. The unit will then return to normal operation.</p>	 <p>OR</p>  <p>OR</p> 	<p>Valid Card:</p>  x1  while door is unlocked	
		<p>Invalid Card:</p>  x1  x1	

4.1 Door Open (Strike) Time

The time period during which the door remains unlocked when either the 'Request to Exit' button is pressed or an authorised card is presented is known as the 'Door Open' or 'Strike' time. A new NanoQuest will have the Strike time set to three seconds, which is suitable for most installations. There may be situations however, where a shorter Strike time may be desirable. For example, when a NanoQuest is used in conjunction with a turnstile, a Strike time of 500ms may be required. There may also be circumstances where a longer strike time is required. For example, where a door is used by physically disabled people or people carrying goods.











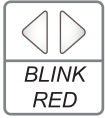

Setting the Door Open (Strike) Time

The Strike time can be set to between one to ten seconds (in one second increments) or to 500ms where a very short strike time is necessary (to control a turnstile, for example). The time should be set to the most suitable value according to the particular installation.

When setting the Strike time, ensure that sufficient time is allowed for authorised staff to open the door but try to avoid using an excessive Strike time, thereby minimising the possibility of unauthorised

personnel gaining access through the unlocked door after an authorised person has entered.

The procedure for setting the strike time is as follows:

Description	Action	Indication	Final State
<p>1) Enter 'Relay Strike Time' mode by presenting the Master nine times.</p> <p>The LED blinks green and the unit beeps twice to indicate programming mode has been entered successfully. The LED then blink green once and the unit beeps once on the second and subsequent presentations.</p> <p>The LED repeat a sequence of 9 red flashes followed by a pause to indicate Mode 9.</p>	 <p>x9</p>	<p>First presentation:</p> <p>x1  x2</p> <p>Second and subsequent presentations:</p> <p> x1  x</p>	<p> x9</p> <p>Followed by a pause. Sequence is repeated.</p>
<p>2) Present a valid User or Auxiliary card once for each second of Door Open (Strike) Time required (up to 10).</p> <p>If the card is shown an 11th time, the strike time is set to 500ms.</p> <p>If the card is shown a 12th time, 'Toggle Lock' Mode is selected (see explanation below).</p>	 <p>xt</p> <p>t = required strike time in seconds</p>	<p>For each card presentation:</p> <p> x1  x1</p>	<p> xt</p> <p>Followed by a pause. Sequence is repeated.</p>
<p>3) Present the original Master card to exit programming mode.</p>		<p> x1  x2</p>	<p> (Operating mode)</p>

While in 'Relay Strike Time' mode , if you do not present any cards for a period of thirty seconds, the NanoQuest will exit programming mode and return to normal operation.

4.1.1. Using Door Open (Strike) in Toggle Lock Mode

With the NanoQuest configured to operate in toggle lock mode, a locked door will be unlocked when a valid User or Auxiliary card is presented. The door will then remain unlocked until a valid User or Auxiliary card is presented again to re-lock it. An example application for this feature is to unlock the door first thing in the morning using a valid card, allowing others free access to the controlled area during office hours. The door can then be locked at the end of the day using a valid card, thereby preventing unauthorised personnel from accessing the controlled area after hours.

Note : Toggle Lock mode affects the way that both the 'Request to Exit' and the 'Door Monitoring' features operate. Read the appropriate section carefully if you intend to use this mode.

4.2 Protecting Multiple Doors

Although the NanoQuest is designed primarily as a standalone access control system, several NanoQuest units may be installed to protect a number of doors using the same User cards. In such an application, it may be desirable to allow certain users access through some doors but not others.

Here is an example:

A small office building has two controlled areas plus the main entrance. All members of staff require access through the main entrance, but access to the controlled areas must be restricted to appropriate staff. The two controlled areas in question are an accounts office and a research laboratory.

Three NanoQuests are fitted, the first to the main entrance, the second to the accounts office and the third to the research laboratory. Cards are added as follows:

Main Entrance: All staff cards plus management cards.

Account Office: Accountants' cards plus management cards.

Research Laboratory: Research staff cards plus management cards.

5. Door Monitoring & Door Alarms

If door contacts are fitted to the door that the NanoQuest is controlling, the NanoQuest can monitor the door and raise an alarm when security has been breached by the door being left open after unlocking or being forced open when it is locked. While an alarm condition is present, the NanoQuest emits regular beeps while the LED flashes amber. The door contacts (closed while door is closed) must be wired to the door contact input of the NanoQuest, and the 'Use door contacts' feature must be enabled.

Door monitoring also provides a more secure way of unlocking the door. Whenever the door is unlocked by the presentation of a valid card or by the 'Request to Exit' button, the moment the door is opened the lock is immediately reengaged (strike relay released) to lock the door as soon as it is closed, regardless of the length of the relay Strike Time. This removes the opportunity for unauthorised personnel to reopen the door after it has been closed in circumstances where a long relay Strike Time has been set.



IMPORTANT

If the Strike relay is set to 'Toggle Lock' Mode when Door Monitoring is used. The 'Door Left Open' alarm does not operate, nor does the lock immediately reengage when the door is opened. However, the 'Door Forced Alarm' will still be raised if the door is detected as being open when in the 'locked' state.

5.1 Door Forced Alarm

The 'Door Forced' alarm occurs when the NanoQuest detects that a door has been opened without being legitimately unlocked by the use of a valid card or the 'Request to Exit' button. This will usually indicate that someone has physically forced the door open.

Once a 'Door Forced' alarm has been triggered, it must be reset by presenting a valid User or Auxiliary card to the Nanoquest. The door must also be closed to completely restore normal operation. If the door remains open after the alarm has been reset, the LED will continue to flash amber and the condition will be treated as 'Door Left Open' (see below).

Door Left Open Alarm

The 'Door Left Open' alarm occurs when a door is left open for longer than ten seconds after the 'door open' time. This alarm is useful for preventing personnel from unlocking a door with a valid User/Auxiliary card or by pressing the 'Request to Exit' button and then 'propping' the door open, thereby compromising the security of the controlled area. When a 'Door Left Open' alarm occurs, the alarm can be cancelled by simply closing the door.

5.2 Alarm Output Operation

The NanoQuest unit has an alarm output that can be connected to an external device such as a siren or flashing light that can be used to draw attention to the door when an alarm condition occurs. The alarm output can also be connected to the alarm input of a CCTV camera, Digital Video Recorder, Video Matrix or similar device to allow your CCTV system to react to the access breach.

The alarm output can be programmed to latch for the duration of the alarm condition or to pulse for one second when the alarm first occurs.

5.3 Door Contacts

5.3.1. Wiring

To identify when the door has been left open or has been forced open and raise an alarm, the door can be monitored by wiring a door contact as shown below.

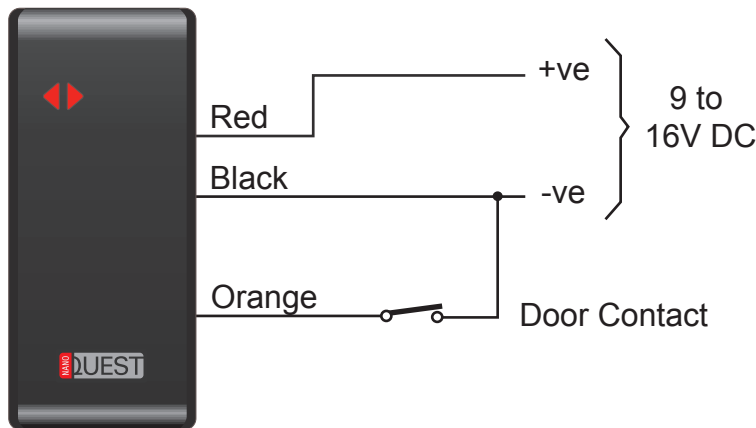







5.3.2. Configuration

It is also necessary to set the 'Door Contact Connected' option using the Master card.

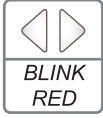
The procedure for activating the door contacts input is as follows:

Description	Action	Indication	Final State
<p>1) Enter 'Use Door Contact' mode by presenting the Master seven times.</p> <p>The LED blinks green and the unit beeps twice to indicate programming mode has been entered successfully. The LED then blinks green once and the unit beeps once on the second and subsequent presentations.</p> <p>The LED repeats a sequence of 7 red flashes followed by a pause to indicate Mode 7.</p>	<p>x7</p>	<p>First presentation:</p> <p>Second and subsequent presentations:</p>	<p>Followed by a pause. Sequence is repeated.</p>
<p>2) Present a valid User or Auxiliary card.</p> <p>The LED blinks green once and then repeat a sequence of single red flashes followed by a short pause to indicate door contact input is disabled.</p>			<p>Followed by a pause. Sequence is repeated.</p>

<p>3) If you wish to enable door contacts, present a valid User or Auxiliary card a second time. Otherwise go straight to step 4.</p> <p>The LED blinks green once and then repeat a sequence of 2 red flashes followed by a pause to indicate door contact input is enabled..</p>		 	 <p>Followed by a pause. Sequence is repeated.</p>
<p>4) Present the original Master card to exit programming mode.</p>		 	 <p>(Operating mode)</p>

While in 'Use Door Contact' mode, if you do not present any cards for a period of thirty seconds, the NanoQuest will exit programming mode and return to normal operation.

5.4 Alarm Output

5.4.1. Wiring

The NanoQuest can be used to drive an external alarm such as a siren or strobe light when a door alarm is raised. This is an open-collector output that is programmable for latch or pulse operation.

Wire the external alarm device as shown below:

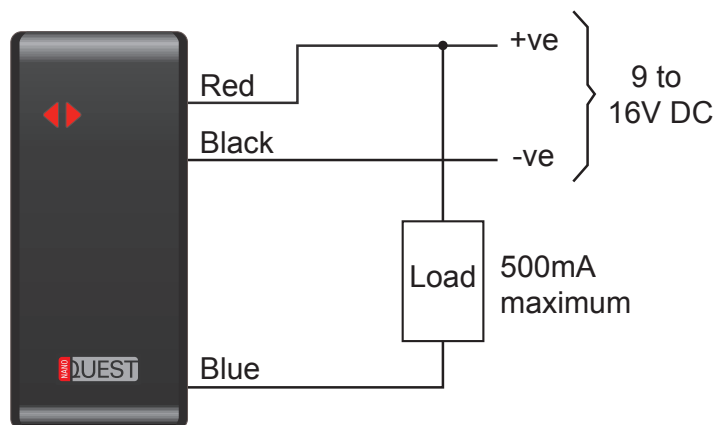

WARNING

To switch mains, inductive loads, or loads drawing more than 500mA, an appropriate intermediate circuit must be fitted (see next page).

Typical Wiring of an external alarm device using an intermediate circuit:

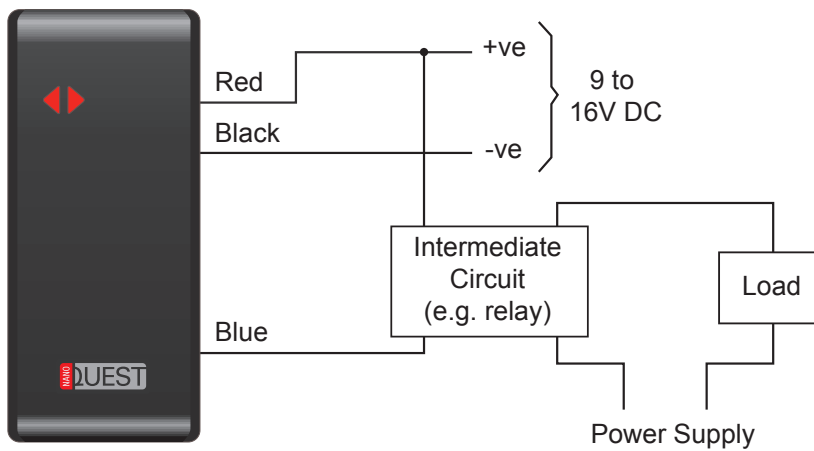









5.4.2. Configuring the Alarm Output

It is possible to configure the alarm output to either latch for the duration of the alarm condition or to give a single one-second pulse when the alarm first occurs. The choice of output depends upon the requirement of the external device that you intend to connect the output to. The factory setting for the Alarm output is to latch. You will only need to change this setting if you need a pulsed Alarm output or if the unit has been used previously and the current settings are not known.

The procedure for setting the Alarm Output mode is as follows:

Description	Action	Indication	Final State
<p>1) Enter 'Configure Alarm Output' mode by presenting the Master five times.</p> <p>The LED blinks green and the unit beeps twice to indicate programming mode has been entered successfully. The LED then blinks green once and the unit beeps once on the second and subsequent presentations.</p> <p>The LED repeats a sequence of 5 red flashes followed by a pause to indicate Mode 5.</p>	<p>x5</p>	<p>First presentation:</p> <p>Second and subsequent presentations:</p>	<p>Followed by a pause. Sequence is repeated.</p>
<p>2) Present a valid User or Auxiliary card.</p> <p>The LED blinks green once and then repeat a sequence of single red flashes followed by a short pause to indicate that 'Latch Mode' has been selected.</p>			<p>Followed by a pause. Sequence is repeated.</p>

<p>3) If you require to set 'Pulse Mode' present a valid User or Auxiliary card a second time. Otherwise go straight to step 4.</p> <p>The LED blinks green once and then repeat a sequence of 2 red flashes followed by a pause to indicate that 'Pulse Mode' has been selected.</p>		 	 <p>followed by a pause. Sequence is repeated.</p>
<p>4) Present the original Master card to exit programming mode.</p>		 	 <p>(Operating mode)</p>

While in 'Configure Alarm Output' mode , if you do not present any cards for a period of thirty seconds, the NanoQuest will exit programming mode and return to normal operation.

6. Controlling Additional Devices

The NanoQuest has the capability to control the activation and deactivation of an additional device using proximity cards. For example, it can be used to arm and disarm an intruder alarm system.









6.1 Using the Auxiliary Output to Operate an Intruder Alarm

In addition to controlling access through a door, the NanoQuest can be used to arm (set) and disarm (unset) an intruder alarm system or similar device via the Auxiliary output. Those members of staff that have been authorised to arm and disarm the alarm should be issued with Auxiliary cards (see Section 3). These cards are able to activate and deactivate the Auxiliary output.

Some intruder alarm systems require the Auxiliary output of the NanoQuest to latch for the period of time that the alarm is armed. Other systems may require a pulse to be used to arm the alarm and a second pulse to disarm it. The Auxiliary output can be set to either 'Latch' or 'Pulse' using the "Configure Auxiliary Output" programming mode.

Some intruder alarm systems also have an output that indicates whether or not the alarm is currently armed and this can be connected to the 'Auxiliary Input' of the NanoQuest (see Section 7). By utilising this feature, the NanoQuest will always keep track of the intruder system status even when it is armed or disarmed manually (i.e. at the alarm panel itself).

Arming and Disarming the Alarm

Description	Action	Indication	Final State
<p>1) Present the same Auxiliary card three times in succession.</p> <p>The NanoQuest beeps once for each of the first two presentations and then beeps three times on the third to confirm that the NanoQuest has output the appropriate condition.</p> <p>The state of the external intruder alarm system will toggle (i.e. if armed it will disarm; if disarmed it will arm)</p> <p>If the Auxiliary input (Section 7) is connected to the status output of the intruder alarm system, upon detection of the change of status of this input, the NanoQuest will output a long beep to provide confirmation to the user.</p>	 <p style="text-align: center;">x3</p>	<p>First Presentation:</p>  x1  <p>Second Presentation:</p>  x1  <p>Third Presentation:</p>  x3  <p>Upon detection of confirmation from the intruder alarm:</p>  x1	<p>Dependant upon strike time setting</p>  <p>(Operating mode)</p>

If the Auxiliary input (Section 7) is connected to the status output of the intruder alarm system, door control is disabled while the alarm is armed so that entry cannot be gained even with an authorised User or Auxiliary card. The alarm must be disarmed first by presenting an Auxiliary card three times in succession. This feature prevents the risk of an authorised person inadvertently entering the building and triggering the alarm.

Note: If the intruder alarm does not provide a status indication to the 'Auxiliary Input', there is no means of confirming its status and therefore the door control can't be disabled. However, if the auxiliary output is set to latching mode, it is possible to connect the auxiliary output condition back into the auxiliary input, thereby disabling the door control when the auxiliary output is active.

6.2 Auxiliary Output Wiring

The NanoQuest can be used to switch on and off an external device such as an intruder alarm or lighting. This is an open-collector output that is programmable for latch or pulse operation.

Wire the external device as shown below:

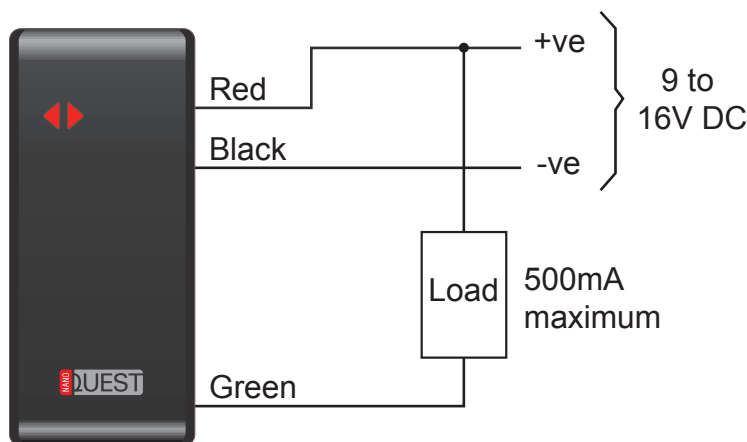

IMPORTANT

To switch mains, inductive loads, or loads drawing more than 500mA, an appropriate intermediate circuit must be fitted (see example below).



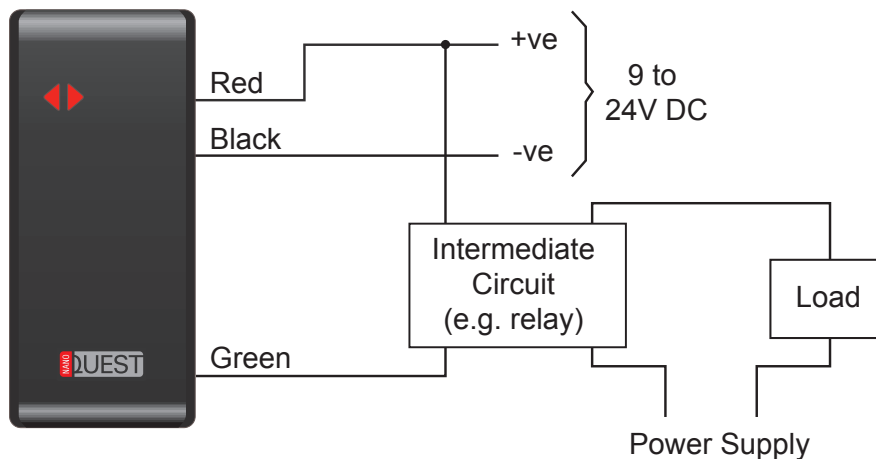





Typical Wiring of an external device using an intermediate circuit:

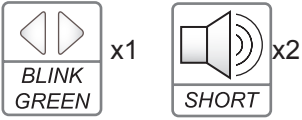
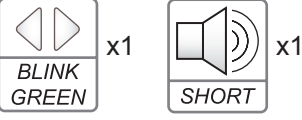
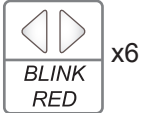

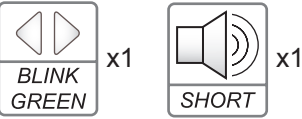
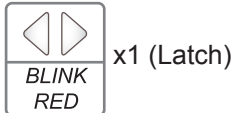
6.3 Configuring the Auxiliary Output

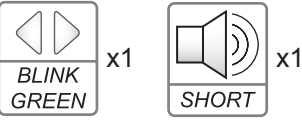
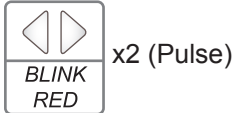
The factory setting for the Auxiliary output is to latch. You will only need to change this setting if you need a pulsed Auxiliary output or if the unit has been used previously and the current settings are not known.

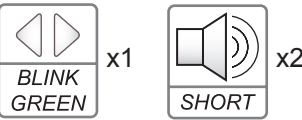
The procedure for configuring the Auxiliary output is as follows:

Description	Action	Indication	Final State
<p>1) Enter 'Configure Auxiliary Output' mode by presenting the Master six times.</p> <p>The LED blinks green and the unit beeps twice to indicate programming mode has been entered successfully. The LED then blinks green once and the unit beeps once on the second and subsequent presentations.</p> <p>The LED repeats a sequence of 6 red flashes followed by a pause to indicate Mode 6.</p>	 <p>x6</p>	<p>First presentation:</p>  <p>Second and subsequent presentations:</p> 	 <p>Followed by a pause. Sequence is repeated.</p>
<p>2) Present a valid User or Auxiliary card.</p> <p>The LED blinks green once and then repeat a sequence of single red flashes followed by a short pause to indicate that 'Latch Mode' has been selected.</p>			 <p>Followed by a pause. Sequence is repeated.</p>
<p>3) If you wish to set 'Pulse Mode' present a valid User or Auxiliary card a second time. Otherwise go straight to step 4.</p> <p>The LED blinks green once and then repeat a sequence of 2 red flashes followed by a pause to indicate that 'Pulse Mode' has been selected.</p>			 <p>followed by a pause. Sequence is repeated.</p>
<p>4) Present the original Master card to exit programming mode.</p>			 <p>(Operating mode)</p>

While in 'Configure Auxiliary Output' mode , if you do not present any cards for a period of thirty seconds, the NanoQuest will exit programming mode and return to normal operation.

6.4 Controlling Other External Devices

The Auxiliary output can be used to control any device that needs a simple on/off signal. This may include lighting, heating, air conditioning, etc, providing an appropriate intermediate circuit is fitted (see section 6.2). Pulse mode is ideal for initiating timed systems such as courtesy lights.

The programming and operation for these applications is as described above.

6.5 Using the Auxiliary Output as a Master Lock

On internal doors that have been fitted with a NanoQuest, it is commonly found that there is no alternative means of securing the door. It may however be necessary at times to prevent authorised Users from entering the a controlled area (outside normal working hours, for example). In this case, if the Auxiliary output is not used to control external devices, it may be used in conjunction with the Auxiliary input (see section 7) to provide a master locking control operated by holders of Auxiliary cards.

To do this, the Auxiliary output should be configured as 'Latching' (see section 6.3) and the Auxiliary Output should be connected directly to the Auxiliary Input (see below):

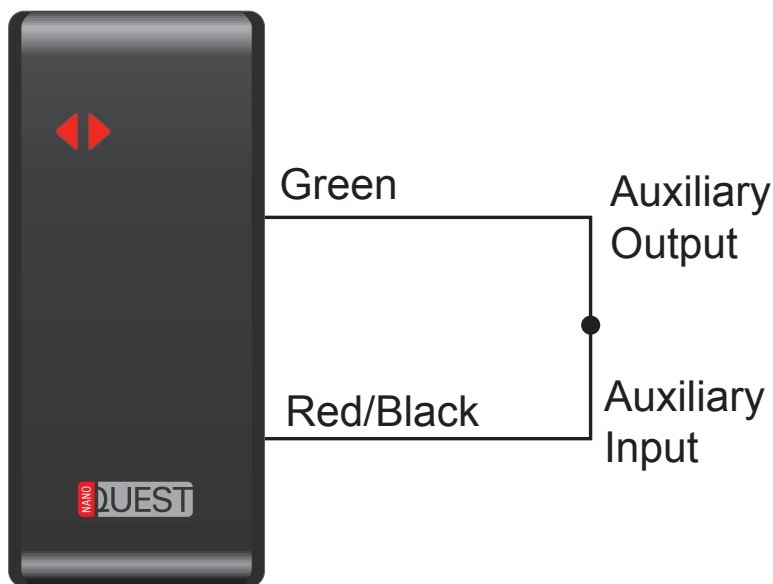

The procedure described in section 6.1 can then be followed to arm and disarm the NanoQuest using an Auxiliary card.

7. Auxiliary Input

The Auxiliary input is used as a means of disabling the NanoQuest relay output while the presence of an external condition is not compatible with Users entering the restricted area. An example of this is when an Intruder Alarm is armed, it would be necessary to prevent authorised personnel inadvertently entering the building and triggering the alarm (see section 6.1).

The use of the Auxiliary input is not restricted to intruder alarm applications. It can be used wherever it is necessary to employ an additional restriction on access. Here are a few examples:

- If the NanoQuest is used for vehicle access, the Auxiliary input can be connected to a vehicle detector to ensure that a vehicle is present when a valid card is presented to the NanoQuest.
- A master key switch can be connected to the Auxiliary input to allow the NanoQuest to be disabled manually by a supervisor.
- Certain access devices such as turnstiles may need to inhibit the strike relay while they are operating.
- In an 'air-lock' configuration where 2 doors are linked and only one of the doors can be open at any one time.

The Auxiliary input does not need to be configured. It simply requires a ground condition to inhibit the operation of the NanoQuest. Therefore the unit will function as normal if the input is not wired.

7.1 Auxiliary Input Wiring

The auxiliary input is used to disable the reader when necessary. It also provides a means of monitoring confirmation from an external device such as an intruder alarm. The contact must be closed to disable access.

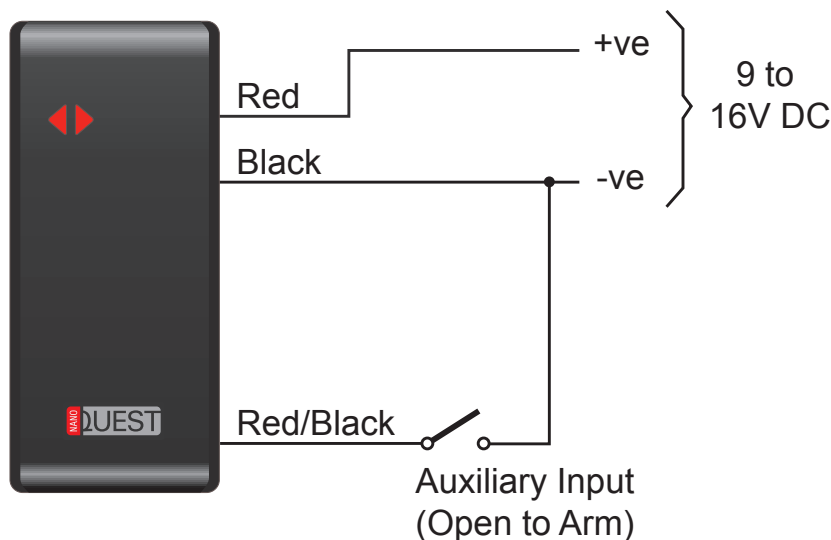

8. Silent Mode



















For certain applications, it may not be convenient for the NanoQuest to give audible indications when cards are presented. It is possible therefore to mute the buzzer by configuring 'Silent Mode'.

When in silent mode, the unit doesn't beep when User cards and Auxiliary cards are presented to it for access, but the buzzer is still active for alarms, auxiliary control and when in programming mode.

The factory default setting for Silent Mode is 'Off' (i.e. the buzzer sounds in normal operation).

8.1 Configuring Silent Mode

The procedure for configuring the Silent Mode is as follows:

Description	Action	Indication	Final State
<p>1) Enter 'Configure Silent Mode' mode by presenting the Master eight times.</p> <p>The LED blinks green and the unit beeps twice to indicate programming mode has been entered successfully. The LED then blinks green once and the unit beeps once on the second and subsequent presentations.</p> <p>The LED repeats a sequence of 8 red flashes followed by a pause to indicate Mode 8.</p>	 <p>x8</p>	<p>First presentation:</p>   <p>Second and subsequent presentations:</p>  	 <p>Followed by a pause. Sequence is repeated.</p>
<p>2) Present a valid User or Auxiliary card.</p> <p>The LED blinks green once and then repeat a sequence of single red flashes followed by a short pause to indicate that 'Silent Mode' is disabled.</p>		 	 <p>Followed by a pause. Sequence is repeated.</p>
<p>3) If you require to enable silent mode, present a valid User or Auxiliary card a second time. Otherwise go straight to step 4.</p> <p>The LED blinks green once and then repeat a sequence of 2 red flashes followed by a pause to indicate that 'Silent Mode' is enabled.</p>		 	 <p>Followed by a pause. Sequence is repeated.</p>
<p>4) Present the original Master card to exit programming mode.</p>		 	 <p>(Operating mode)</p>

While in 'Configure Silent Mode' mode , if you do not present any cards for a period of thirty seconds, the NanoQuest will exit programming mode and return to normal operation.

9. Miscellaneous Features



9.1 General

Previous sections have described the main features of NanoQuest. There are however several additional features available to allow an administrator to overcome problems and to change the functionality of the NanoQuest. Care must be taken when carrying out these tasks as vital information can be lost.

9.2 Deleting all User Cards and Auxiliary Cards

Provided that the original cards are available, User Cards and Auxiliary cards can be deleted from the NanoQuest individually as described in section 3.6. Where it is necessary to delete a card from the system because it has been lost or stolen, the only means of deleting it individually is to use an 'administration' card (captive copy of the card supplied with the original) . However, if cards were purchased without the administration pack, the only option would be to delete all cards from NanoQuest and add all valid cards once again as they are available. This may be carried out either by temporarily collecting in all cards or by an administrator adding the cards as each user attempts to enter the restricted area.

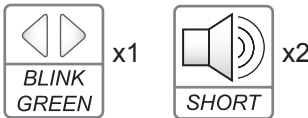
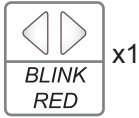
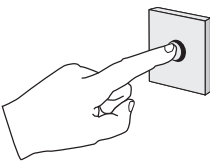
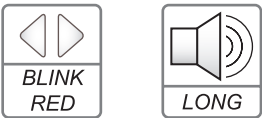
9.2.1. Procedure for Deleting all Cards

Description	Action	Indication	Final State
<p>1) Enter 'Programming Mode' mode by presenting the Master once.</p> <p>The LED blinks green and the unit beeps twice to indicate programming mode has been entered successfully.</p> <p>The LED flashes red regularly to indicate Programming Mode 1.</p>			 <p>Followed by a pause. Sequence is repeated.</p>
<p>2) Press and hold the 'Request to Exit' button for at least ten seconds. (If the 'Request to Exit' button isn't fitted, connect the white/black wire to ground for at least 10 seconds).</p> <p>After ten seconds, the unit will output a long beep. Release the button.</p>		<p>After 10 seconds:</p> 	 <p>(Operating mode)</p>









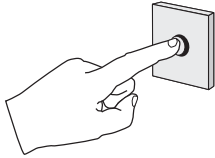

9.3 Resetting to Factory Default Settings

If it is ever necessary to recover from an unknown state or if both Master cards have been lost or stolen, there is an option to reset the NanoQuest to its initial settings. This will delete all cards including the Master cards, and all parameters will be set to the way they were when the NanoQuest was new. The default values are shown below:

Item	Factory Default
Number of Master Cards	0
Number of User Cards	0
Number of Auxiliary Cards	0
Alarm Output Configuration	Latch
Auxiliary Output Configuration	Latch
Door Contact Input Connected	Not Connected
Silent Mode	Off
Door Open (Strike) Time	3 Seconds

Note: When the NanoQuest is shipped, it comes with 2 Master cards. After a full reset, these cards are no longer stored so they will need to be added once more. If the original Master cards are no longer available, any unassigned card can be programmed as a Master card. Ensure that they are clearly marked and kept safe.

9.3.1. Performing a Factory Reset

Description	Action	Indication	Final State
1) Power down the unit.	 Off		
2) Press and hold the 'Request to Exit' button. Power up the unit and keep the 'Request to Exit' button pressed for at least ten seconds. (If the 'Request to Exit' button isn't fitted, connect the white/black wire to ground). After ten seconds, the unit will output a long beep. Release the button. The LED alternates between red and green.	  On	 STEADY RED After 10 seconds:  LONG then  STEADY RED	Upon release of RTE button:  BLINK RED  BLINK GREEN Alternating.
3) Present the card that you wish to make your first Master card.		 SHORT x2	 STEADY RED (Operating mode)

If the 'Request to Exit' button is released before ten seconds has passed, the unit does not reset and remains in normal operation mode.

9.4 Wiegand Data Output Option

The NanoQuest is able to output card data to an external controller so that it can act as a standard card reader. This feature allows a NanoQuest installation to be expanded to a larger, centrally controlled system without the need to replace the NanoQuest with another reader. All existing cards can still be used on the new system.

To operate in Wiegand output mode, the NanoQuest must be connected as shown below:

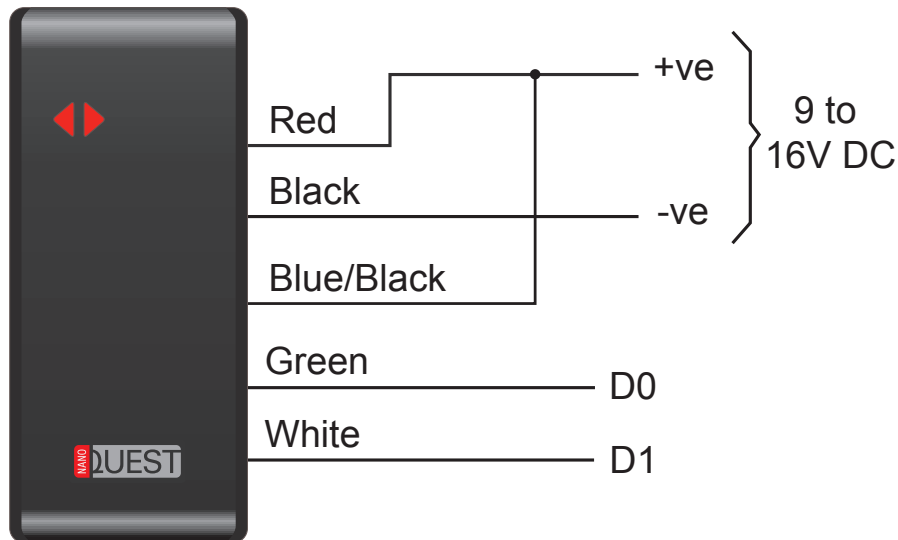

The unit must be powered down, rewired and then powered up again. The standalone functions are no longer supported and, when a card is presented, it simply reads the card and forwards the card number to the external access controller.

9.5 RS232 Data Output

If you require the NanoQuest to send card data over a serial link to an external device, in addition to the other connections, wire the RS232 Tx lead and ground to the RS232 input of the external device:

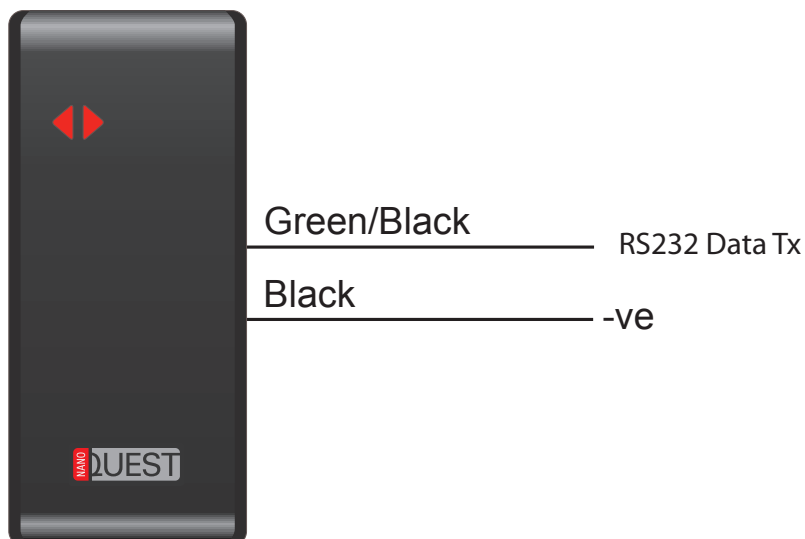

10. Technical Specifications

Electrical

Supply Voltage: 9V DC to 16V DC

Current Requirement: < 70 mA

Physical

Dimensions (mm): 111 x 49 x 19 (H x W x D)

Colour: Standard = charcoal grey

Material: ABS polycarbonate

Rating: IP65 - suitable for outdoor and indoor use

Environmental

Operating Temperature: -30°C to 50°C Ambient

Outputs

Strike Relay: Change-over contacts rated at 1A at 30V DC. Programmable strike time 0.5 to 10 seconds or latching.

Auxiliary Output: Open-collector output for auxiliary control (latch or pulse options)

Alarm: Open-collector output for external alarm (latch or pulse options)

Wiegand Data: 26-bit Wiegand data for use with external controller

Serial Data: RS232 (10 digits plus CR) for use with external monitoring system/ controller

Inputs

Free Exit: Clean contact, ground to activate

Auxiliary/Arming: Clean contact, ground to disable, open contact to enable

Door Monitor: Clean contact, ground to indicate door closed (if activated)

Card Types

Master Card: Used for Configuration and adding/removing User cards

User Card: Used to gain access to restricted area

Auxiliary Card: Used to gain access to restricted area and to activate auxiliary devices

Connection

Pigtail Cable Length: 300mm as standard - 3m option available on request

Conductors: 15

Operational

Reading Range: Up to 80mm depending upon the type of card or token

Buzzer: On/Off selectable

Indicators: Tri-colour LED