

RH300 High Specification Magstripe Reader

Product Description

The RH300 magstripe readers provide high-performance and reliability for any application; whether high-security access control, electronic point of sale, time and attendance or purely data acquisition. A wide variety of output formats are available to provide flexibility for most OEM applications.

The RH300 magstripe reader is manufactured from impact resistant UV stabilised acrylic. Being made from such hard wearing material not only means that the product is very durable, but also ensures that even in the harshest conditions the reader continue to operate.

As all the electronics are embedded in epoxy resin this product is weather-proof and vandal-resistant – making it an ideal choice for both indoor and outdoor use. The reader heads provide an extremely reliable reading capability with over 1 million head passes.

The single tri-colour LED provides a visual indicator-showing the current reader status, whilst the internal buzzer provides an audible indicator. Both indicators are utilised via external lines.



Features

- ▶ Stainless steel fixing plate with internal/external secure fixing
- ▶ Reliable read capability with head life in excess of 1 million passes
- ▶ Available as Track 1, Track 2 or Track 3 ISO
- ▶ Weatherproof, suitable for outdoor use
- ▶ Vandal-resistant
- ▶ Card speed is 125 to 380 cm per second
- ▶ Data range 325 to 12,250 bits per second
- ▶ All electronics are encapsulated in epoxy resin (except read head and buzzer aperture)
- ▶ Reads lo-co and hi-co magnetic-stripe cards
- ▶ CMOS Clock, Data and Card Present outputs (see technical data)

Specifications

Electrical

Supply Voltage: +5VDC to +18VDC – recommended +12VDC

Current Reqmt: 50mA at +5VDC and 20mA at +12VDC

Physical

Connections: Reader supplied with 2.5 metre - 8 core screened cable

Cable Distance: Maximum of 100 metres – 24AWG (7/0.20)

LED & Buzzer: Control Inputs: 0 to +5VDC maximum.

Visual Indication: Single tri-colour LED normally red, green and yellow activated via external line

Finish: Black UV Acrylic

Dimensions: 112 x 42 x 36mm

Environmental

Operating Temp: -25°C to 65°C

RH300 High Specification Magstripe Reader

Technical Data

Cable Connections:

Red	+VDC Supply
Blue	Card Present
Green	Clock (or Wiegand Data 0)
Yellow	Buzzer Control Line
White	Data (or Wiegand 1)
Black	0VDC Signal Ground
Violet	not in use
Orange	Green/Yellow LED Control Line

Standard Clock and Data Output—Signal Format

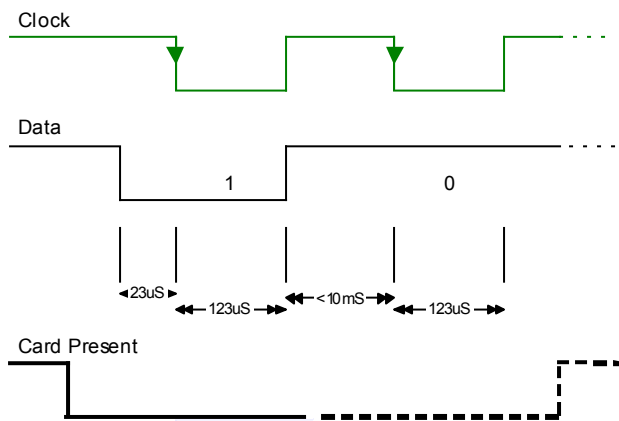

Wiegand Output—Signal Format

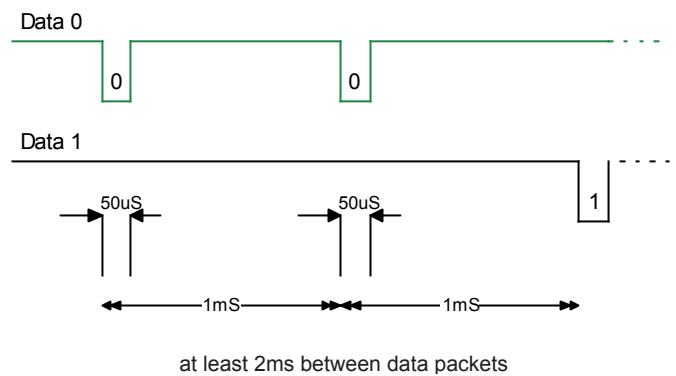

This diagram represents active 'Low' CMOS clock, data and card present. On the data line, the 'high' level indicates a data '0' bit and the 'Low' level denotes a data '1' bit. Data must be accepted at the falling edge of the Clock pulse. The timings shown are for guidance purposes only and will in practice vary in accordance with the card speed.

Ordering Information

RH300-x Where x signifies the output type.

Output Types:

- 2—Clock & Data
- 3—Wiegand 26 bit
- 4—Wiegand 36 bit
- 5—Wiegand 50 bit

Track 2 as standard — also available Track 1 or Track 3 (please specify when ordering).