

## PD280 Dual Channel Advanced Slimline Vehicle Detector

### Product Description

The 8 series, Nortech's new flagship Parking Vehicle Detector, addresses the market's need for a slimline, advanced vehicle detection solution. The powerful architecture facilitates sophisticated algorithms ensuring robust and reliable detection every time. The relay and opto outputs are fully configurable, allowing for alarms and alerts on desired events. Nortech's Automatic Frequency Selection (AFS) algorithms have been refined and optimised resulting in simplified setup and installation of complex multi-lane traffic sites.

The new DU800 wireless diagnostic unit allows for detector configuration and installation feedback of 8 series detectors on any iOS or Android device. This eliminates the need to adjust any mechanical interfaces once the unit has been installed. The DU800 also allows for vehicle profile streaming.

The new slimline, DIN Rail mount housing allows for more physical connections than the traditional relay base.

Like its forebears, the 8 series detectors simply work, offering peace of mind in even the most complex installation.

The PD280 supports two loops with either relay or opto outputs.

### Applications

- ▶ Parking barrier control
- ▶ Safety Loop
- ▶ Arming Control
- ▶ Motorised gates and doors
- ▶ Industrial control systems

### Features

- ▶ **Slimline Form** - The PD280 is the slimmest of the Nortech parking detectors facilitating installation in even the most physically constrained environments.
- ▶ **AFS** - Automatic Frequency Selection (AFS) automatically examines the detector environment and sets the optimal operating frequency to ensure minimal interference and maximum reliability, significantly decreasing installation time. Frequency can also be manually set via wireless configuration channel.
- ▶ **PowerFail Memory** - In the event of a power failure, the PD280 will retain the presence of the vehicle when power is restored. The PD280 is also able to determine if a vehicle has driven onto the loop while the power is off, and detect it immediately when the power returns. This is most useful in applications where damage to vehicles could occur (e.g. Rising Bollards). The PowerFail memory is infinite.
- ▶ **Diagnostics** - Comprehensive, wireless diagnostics allow for accurate diagnosis of loop and installation problems as well as configuration adjustments to eliminate issues. This is made possible via Nortech's DU800 and App.



### Specifications

<b>Self-tuning Range:</b>	20µH to 1500µH
<b>Sensitivity:</b>	Ranging from 0.01% ΔL/L to 5% ΔL/L. Automatic Sensitivity Boost (ASB) is selectable per channel.
<b>Frequency:</b>	Automatic Frequency Selection (AFS) or select from 6 frequency bands per channel 30 -150 kHz (Frequency is determined by loop geometry).
<b>AFS:</b>	Automatically evaluates all frequency bands on startup and selects the most suitable in the given environment based on signal strength and noise.
<b>Response time:</b>	Detect: < 58ms ±1.5ms Undetect: < 58ms ±1.5ms
<b>Presence Time:</b>	Permanent or limited selectable per channel
<b>Drift Compensation:</b>	Incorporated method of tracking changes caused by environmental conditions at a rate approximating 1% ΔL/L per minute
<b>Anti-locking:</b>	Incorporated algorithm accommodates the influence of positive inductance changes to avoid detector lock-up
<b>Relay Outputs:</b>	2 programmable relays with NO, NC and COM connections exposed. Options for presence or pulse, pulse on detect, undetect or fault and each relay has configurable Filter, Delay and Extend options
<b>Relay Mode:</b>	Relays can be configured to operate as Fail Safe or Fail Secure
<b>Opto Outputs:</b>	3 Opto outputs provided as an alternative to relays. Each is individually configurable.
<b>Protection:</b>	Polarity protection, loop isolation transformer, zener diode clamping, gas discharge tubes, 50-60Hz Noise Rejection
<b>Power:</b>	12 - 24V ±10% (AC/DC) 90V - 230V ±10% AC 50/60 Hz
<b>Connections:</b>	DIN Rail mount 3 x 3 Way Connectors and 1 x 4 Way connector Operating
<b>Temp.:</b>	-40°C to +80°C
<b>Dimensions:</b>	Maximum outer dimensions are 94mm x 94mm x 22.5mm

# PD280 Dual Channel Advanced Slimline Vehicle Detector

## Indications

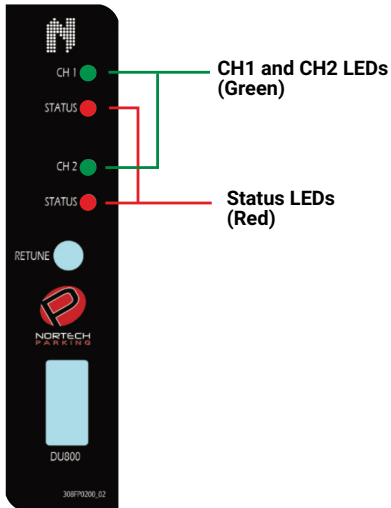

LED State	Indication
On	Channel is in Detect
Off	Channel is in Undetect

LED State	Indication
Flashing rapidly	Channel is busy tuning to the loop
Fast constant flashing	Channel is in fault
Slow constant flashing *	Detector is in firmware update mode
ON	Detector is on and tuned to the loop
OFF	Channel is disabled or detector is not powered

\* Only the top Status LED will flash on dual channel detectors when the detector is in firmware update mode.

## Output Options

Failure Mode (safe/secure)

Operation Mode (presence/pulse)

Triggers:

Pulse Mode	Presence Mode
Detect	Detect
Fault	Fault
Master Fault†	Master Fault†
AB Logic Forward	AB Logic Forward
AB Logic Reverse	AB Logic Reverse
Undetect	

† This option is only suitable for Opto outputs

## Connections

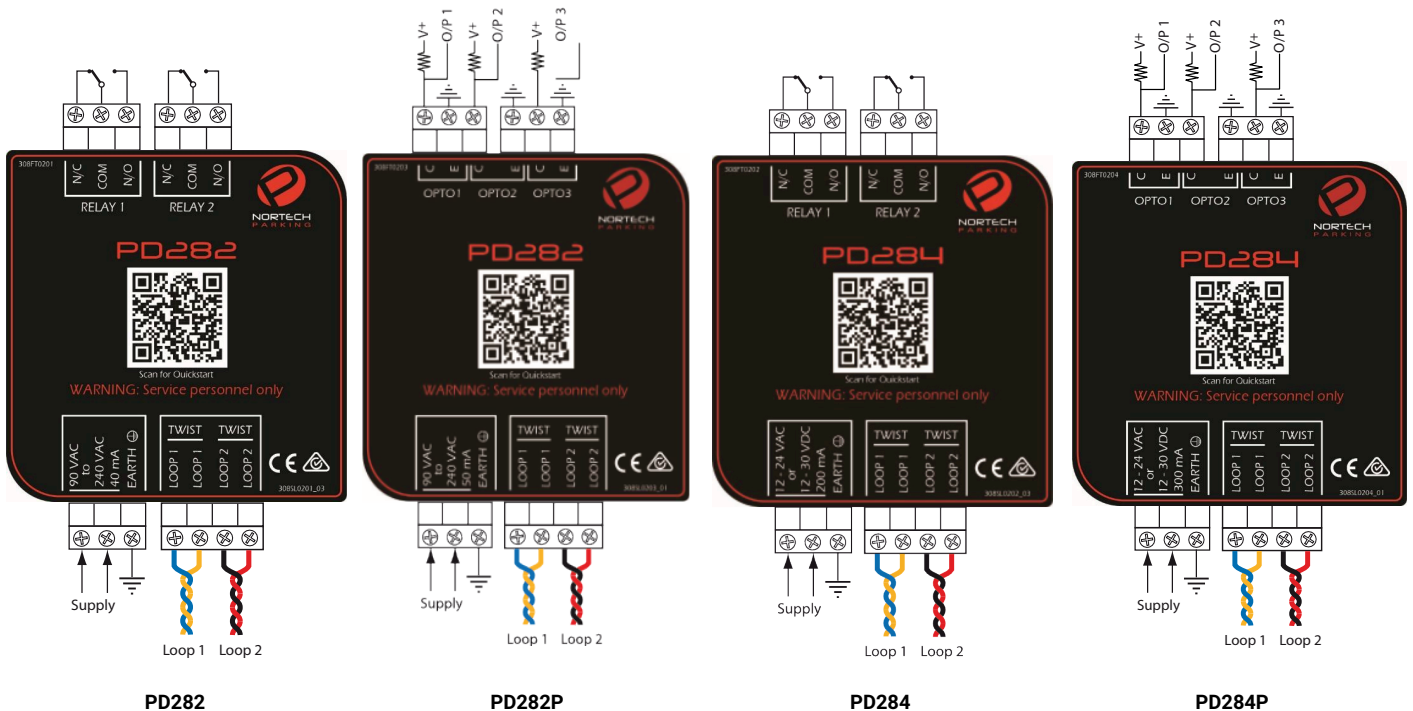

## Ordering Information

PD282	Dual Channel 90 - 230V AC	PD284P	Dual Channel 12 - 24V AC/DC with opto outputs
PD282P	Dual Channel 90 - 230V AC with opto outputs	DU800	Diagnostic unit for 8-Series detectors
PD284	Dual Channel 12 - 24V AC/DC		